

EMTOMECC

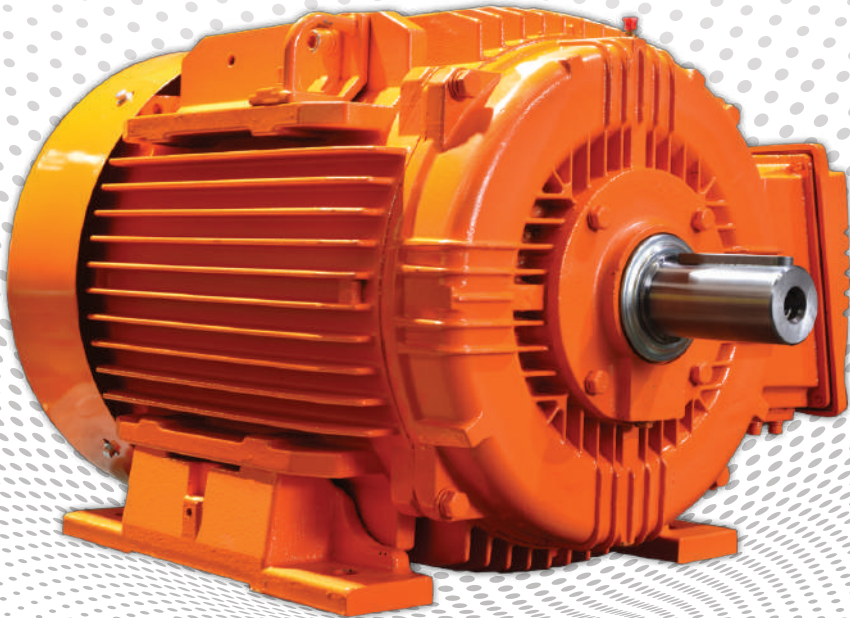

ELECTRIC MOTORS

Premium Series | High Efficiency | Low Voltage Motors

Technical Brochure

EMT OMEC – A GLOBAL PLAYER

EMT is a global multinational group of companies linked together by common products and markets. EMT OMEC is the group's Electric Motor and Motor Service company located in Australia. Our Electric Motors are manufactured by our partner company OMEC another global player with manufacturing and distribution footprints stretching across Asia, Europe, Australia and Africa.

EMT OMEC M3 PREMIUM SERIES ELECTRIC MOTOR

“Designed and Manufactured for Long Life & Lower Total Cost of Ownership.”

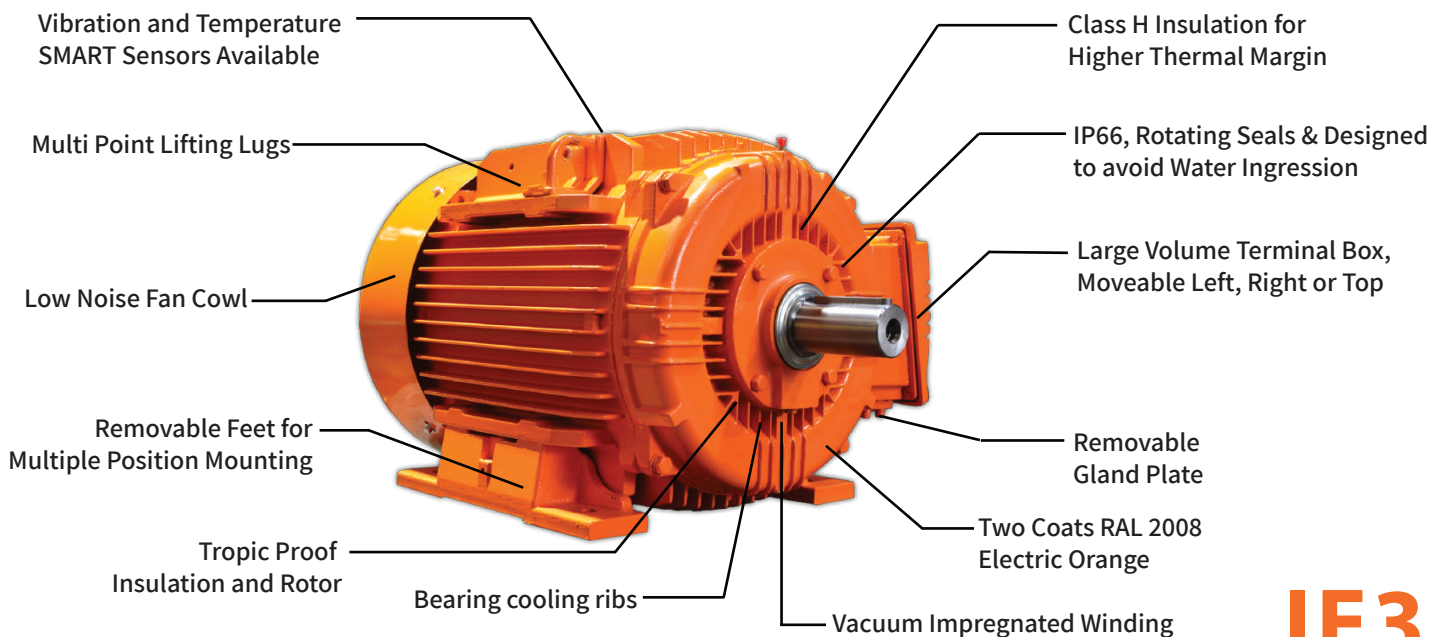

IE3

PREMIUM SERIES MOTORS

IE3 High Efficiency

Technical characteristics

- ☑ IE3 high efficiency rated motor series
- ☑ Design & Performance proven to IEC 60034 standards
- ☑ IP 66 enclosure rating, fixed and rotating seals
- ☑ Class H insulation with maximum B rise.
- ☑ Vacuum impregnated winding for Durability, Long Life and Lower Cost of Ownership.
- ☑ S1 duty at 1000m AMSL and 40 °C ambient.
- ☑ No de-rating between -20 and +40 °C
- ☑ Dual voltages 415V / 690V, 50Hz / 60Hz
- ☑ Tested to 1.5 times FLC for 2 minutes
- ☑ Ratings upto 355kW and larger on request
- ☑ High quality cast iron TEFC frames to IEC dimensions
- ☑ Bearings are re-greasable, heavy duty 63 series C3 clearance
- ☑ Replaceable feet on M3 frames 160 to 280 frames
- ☑ M3 design allows for top or left hand conversions from standard RHS
- ☑ Terminal box rotatable in 90 ° intervals for left, right or top cable entry
- ☑ Diagonal terminal lid, easy access on installation
- ☑ Mounting options B3, V6, V5, B5, V3, V1, B35, B36 or V15
- ☑ Variable mount lifting lugs for easy handling
- ☑ IEC vibration Grade N as standard
- ☑ Two coat wet spray finish gloss RAL 2008 Tropic Proof design
- ☑ Steel Fan cowls – heavy duty versions on request
- ☑ Hi impact static resistant injection moulded fans
- ☑ Insulated bearings and earth brushes for VSD applications available
- ☑ 150 / 180 °C Thermistors standard in aux terminal box
- ☑ PT 100 thermal protection available
- ☑ Forced ventilation units available
- ☑ Anti condensation heaters available
- ☑ Tacho generator and encoders available
- ☑ Vibration and Temperature Smart sensors available
- ☑ 3 plus Warranty

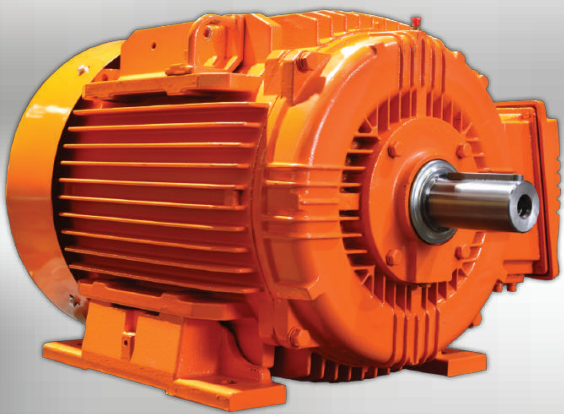

OUR PRODUCTS

EMT OMEC manufactures and distributes a wide range of high quality Electric Motors and related products to many global standards across most market segments throughout the Australian market. All products are manufactured to meet and exceed applicable international and local standards. In addition, they have many performance and construction features that are specifically designed to cope with Australia's unique local environmental and application requirements.

This product brochure describes EMT OMEC M3 Premium series cast iron motors and larger Y2 series cast iron IE3 motors. These motors have been developed to exceed the needs of our clients operating within an energy environment of increasing complexity where energy utilisation economics are driving technological advances and by default purchasing decisions relating to total cost of ownership. These high efficiency motors are designed to meet the requirements described in both the Australian minimum efficiency standards and international IEC 60034 (IE3) performance standards. These motors are increasingly the go to product for the discerning motor buyer when key application requirements requiring robust mechanical properties as well as high standards of electrical performance, ensuring the efficient use of energy and a low resultant low carbon footprint are important decision factors

ENERGY EFFICIENCY

Energy and energy efficiency are terms we see everywhere across industry, however the concept is often over complicated and sometimes misunderstood. The simplest way of understanding energy utilisation in terms of an electrical motor is that its efficiency is just the ratio of mechanical output power to the electric input power.

The laws of nature predict that any piece of machinery will to some degree incur energy losses due to mechanical friction, heat loss and electrical losses. The higher the efficiency of the machines design, the lower the losses. This is important because you are paying for the energy you put into an electric motor not the mechanical power it puts out. Lower the input electrical power in billable Kilowatts and you directly reduce your electricity bill.

In recent years, advances in material science in combination with computer aided design technology has allowed engineers to optimise Electric Motor design and reduce these losses to as little as 4% in the best scenarios. It was not uncommon in years past to see larger motors losing over 20% of their input power to poor design.

To put this into perspective an IE1 efficiency 75kW motor at full load has an efficiency around 92,7% need input power of almost 81kW. You're paying for 81kW. By comparison an EMT OMEC IE3 motor has an efficiency exceeding 95% need input power of only 79kW. This may seem to be an inconsequential improvement, however you save over 2kW an hour for 10 hours a day for 20 days a month that's $2 \times 10 \times 20 = 400\text{kWh}$ a month you're not paying for. Actually, it is a staggering 4,8MWh a year saving. Eyes wide open now? In reality the 2,4% loss saving between new technology and old technology represents an impressive 31% reduction in energy wastage on one such motor alone. How many old motors do you have on your works site? Now this concept starts to make practical sense.

EFFICIENCY REGULATION

To ensure these energy efficiency savings are maximised by industry, and in doing so inversely reducing generation demand needs, our government has implemented minimum energy efficiency standards for electric motors. The older IE1 efficiency motors used in the above example were commonly sold well into the mid 2000's until legislation prevented further import or manufacture after 2006. Many thousands of these inefficient motors remain installed throughout industry. Revised national standards have now raised the minimum efficiency across a wide range of industrial electric motors to a level generally termed as IE2. Above this level is a far higher specification of motor with an IE3 level of efficiency. These are now termed high efficiency motors. EMT OMECs Premium series of cast iron electric motors as described within this brochure either meet or exceed the requirements of the higher IE3 efficiency standards.

NATIONAL ELECTRIC MOTOR STANDARDS

Our Premium series EMT OMEC IE3 high efficiency electric motors are manufactured and perform in accordance with the below mentioned national and International standards.

| | |
|---------------|--|
| AS 60034.1 | Rotating electrical machines - Rating and Performance |
| IEC 60034-2-1 | Rotating electrical machines - Standard methods for determining losses and efficiency |
| AS 60034.5 | Rotating electrical machines - Degrees of protection provided - IP code |
| IEC 60034-6 | Rotating electrical machines - Methods of cooling - IC code |
| AS 60034.7 | Rotating electrical machines - Construction, mounting and terminal box positions - IM code |

| | |
|--------------|---|
| AS 60034.8 | Rotating electrical machines - Terminal markings and direction of rotation |
| AS 60034.9 | Rotating electrical machines - Noise limits |
| AS 60034.11 | Rotating electrical machines - Thermal protection |
| AS 60034.12 | Rotating electrical machines - Starting performance of single-speed induction motors |
| IEC 60034-14 | Rotating electrical machines - Mechanical vibration limits |
| IEC 60034-30 | Rotating electrical machines - Efficiency classes for single speed three-phase cage induction motors |
| IEC 60072-1 | Dimensions and output series for rotating electrical machines - Frame numbers 56 to 400 and flange numbers 55 to 1080 |

TYPE DESIGNATION

EMT OMEC M3 and Y2 series IE3 motors are identified by standard part codes as detailed below.

Example an IE3 Premium series 75kW 4P motor would be termed PHE 250M4 B3 where the data indicates

| | |
|------|----------------------------|
| P | Premium IE3 series |
| HE | High Efficiency |
| 250M | Motor Frame size |
| 4 | Poles - Speed 2, 4, 6 or 8 |
| B3 | Mount type B3, B35 or B5 |

Each designation is unique to individual rating. The Motor rating plate designates the kW rating particular to the indicated Type Designation

PRODUCT IDENTIFICATION NAMEPLATES

All EMT OMEC Premium series cast iron high efficiency motors are equipped with stainless steel rating plates riveted to the main motor casing on which all relevant ratings, performance and supply connection related identification data is permanently engraved.

| EMTOME C | | Three Phase Motor | | IE3 | | |
|-----------------------|----------------|-------------------|--------------------|-----------|------------|--|
| Type | IE3-315M4 | | Ins. CL H | Duty S1 | IP 66 | |
| V Δ/Y | Hz | KW | RPM | A Δ/Y | Pf | |
| 380 / 660 | 50 | 132 | 1485 | 238 / 137 | 0.88 | |
| 415 / 720 | 50 | 132 | 1485 | 223 / 129 | 0.86 | |
| 440 / 760 | 60 | 158 | 1785 | 252 / 143 | 0.88 | |
| 500 / 865 | 60 | 158 | 1785 | 227 / 131 | 0.86 | |
| Weight | 1053 kg | | Brg DE | 6319C3 | PTC 150°C | |
| Alt 1000mt | AMB. 40°C | | Brg NDE | 6319C3 | PTC 180°C | |
| Serial No | xxxxxxxxxxxxxx | | Δt 80K | IEC 60034 | ASNZ1359.5 | |
| EMTOME C 1300 139 181 | | | www.emtomec.com.au | | | |

MOUNTING ARRANGEMENTS

The EMT OMEC Premium series cast iron high efficiency motors are designed so that they can be operated in all horizontal and vertical mounting positions, providing consideration is given to the location of drain holes and bearing types specified for application loads. The M3 design also incorporates removable mounting feet across frames 160mm to 280mm allowing for B3, B35 and B5 only frame configurations.

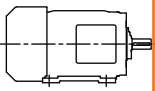
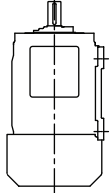
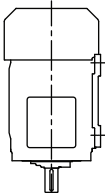
| MOTOR MOUNTING STANDARDS | | | |
|--------------------------|---|---|---|
| Mount Orientation |  |  |  |
| Mount | Horizontal | Shaft Up | Shaft Down |
| Foot Mount | B3 - IM1001 | V6 - IM1031 | V5 - IM1011 |
| Foot & Flange Mount | B35 - IM2001 | V36 - IM2031 | V15 - IM2011 |
| Flange Mount | B5 - IM3001 | V3 - IM3031 | V1 - IM3011 |

TERMINAL BOX

These Premium series motors have cast iron IP66 terminal boxes with gaskets. The angled profile of the box section allows for easy access to the terminal studs and facilitates easier tightening. The dome profile lids also allow additional internal clearances. The gland plates on all frames are removable greatly cutting installation time. Each terminal box is rotatable in 90° intervals allowing for any cable entry direction.

The removable mounting feet across the M3 series 160 to 280 frames allows the standard right hand terminal box to be converted to a top or left hand terminal box location with relative ease. The terminal blocks are centrally located above the cable seal that separates the internal motor body space from the terminal box interior. The motor main leads are marked in accordance with the requirements of IEC60034-8.

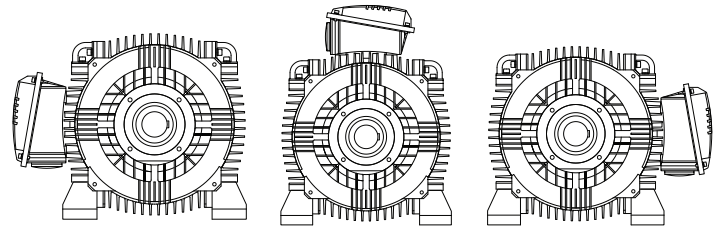

| TERMINAL BOX GLAND ARRANGEMENT | | | |
|--------------------------------|----------------|-----------|---------|
| Motor Frame | Design Type | Gland Qty | Size |
| 160 | M3 - Removable | 2 | M32x1.5 |
| 180 | M3 - Removable | 2 | M32x1.5 |
| 200 | M3 - Removable | 2 | M50x1.5 |
| 225 | M3 - Removable | 2 | M50x1.5 |
| 250 | M3 - Removable | 2 | M63x1.5 |
| 280 | M3 - Removable | 2 | M63x1.5 |
| 315 | Y2 - Removable | 2 | M63x1.5 |
| 355 | Y2 - Removable | 4 | M63x1.5 |

DUTY RATINGS

All EMT OMEC Premium series cast iron high efficiency motors are rated for continuous duty S1. Where motors are required to meet the needs of S2 to S9 duty applications please contact our offices for assistance.

AMBIENT x ALTITUDE APPLICATION

In accordance with the requirements of IEC 60034-1, this Premium series of electric Motor is listed in its standard format based upon an ambient temperature range of -20°C to 40°C ambient and altitudes up to and including 1000mts.

Although our class H insulation systems provide more thermal margin protection than can be found in many standard industrial motors. It is however still good practice to assume that when motors are intentionally used outside of these standard installation parameters some de-rating may be sensible. This de-rating scenario can be applied using the table below.

| ALTITUDE (m) | | | | | | | | | |
|--------------|------|------|------|------|------|------|------|------|------|
| T (°C) | 1000 | 1500 | 2000 | 2500 | 3000 | 3500 | 4000 | 4500 | 5000 |
| 10 | | | | | | | 0.97 | 0.92 | 0.88 |
| 15 | | | | | | 0.98 | 0.94 | 0.90 | 0.86 |
| 20 | | | | | 1.00 | 0.95 | 0.91 | 0.87 | 0.83 |
| 25 | | | | 1.00 | 0.95 | 0.93 | 0.89 | 0.85 | 0.81 |
| 30 | | | 1.00 | 0.96 | 0.92 | 0.90 | 0.86 | 0.82 | 0.78 |
| 35 | | 1.00 | 0.95 | 0.93 | 0.90 | 0.88 | 0.84 | 0.80 | 0.75 |
| 40 | 1.00 | 0.97 | 0.94 | 0.90 | 0.86 | 0.82 | 0.80 | 0.76 | 0.71 |
| 45 | 0.95 | 0.92 | 0.90 | 0.88 | 0.85 | 0.80 | 0.78 | 0.74 | 0.69 |
| 50 | 0.92 | 0.90 | 0.87 | 0.85 | 0.82 | 0.80 | 0.77 | 0.72 | 0.67 |
| 55 | 0.88 | 0.85 | 0.83 | 0.81 | 0.78 | 0.76 | 0.73 | 0.70 | 0.65 |
| 60 | 0.83 | 0.82 | 0.80 | 0.77 | 0.75 | 0.73 | 0.70 | 0.67 | 0.62 |
| 65 | 0.79 | 0.76 | 0.74 | 0.72 | 0.70 | 0.68 | 0.66 | 0.62 | 0.58 |
| 70 | 0.74 | 0.71 | 0.69 | 0.67 | 0.66 | 0.64 | 0.62 | 0.58 | 0.53 |
| 75 | 0.70 | 0.68 | 0.66 | 0.64 | 0.62 | 0.60 | 0.58 | 0.53 | 0.49 |
| 80 | 0.65 | 0.64 | 0.62 | 0.60 | 0.58 | 0.56 | 0.55 | 0.48 | 0.44 |

DEGREE OF PROTECTION

The EMT OMEC Premium motor series is designed with an IP66 enclosure rating according to the requirements of IEC60034.5. This is accomplished via the use of a dual fixed and rotating seal design at both the drive and non-drive end of the motor frame. The outer seal provides a rotating labyrinth and lip seal whilst the inner seal acts as a mechanical oil seal. The motors terminal box is also rated IP66 with a closed cell gasket between all joint surfaces.

| IP | 6 | 6 | Dust and Water protection standards |
|--|---|---|-------------------------------------|
| Numeral 1 | 1 | 2 | |
| 2: Motors protected against solid objects greater than 12 mm | | | |
| 4: Motors protected against solid objects greater than 1 mm | | | |
| 5: Dust-protected motors | | | |
| 6: Dust-tight motors | | | |
| Numeral 2 | | | |
| 3: Motors protected against spraying water | | | |
| 4: Motors protected against splashing water | | | |
| 5: Motors protected against water jets | | | |
| 6: Motors protected against heavy seas | | | |

COOLING

All EMT OMEC Premium series high efficiency motors are totally enclosed fan cooled (TEFC) IC411 designs to IEC60034-6. Standard cooling fans are injection moulded reinforced polypropylene. All motors can be equipped with alloy or steel fans on request when required. All fans are bi-directional in design allowing all motors to be run either clock-wise or anti-clockwise without modification. Fan covers are all steel construction.

Certain applications require special cooling arrangements. For eg. forced ventilation cooling units to provide constant air cooling at lower operating speeds. EMT OMEC Premium series motors can be upgraded to include these modifications and other special cooling upgrades.

Specific attention needs to be taken to the air space behind and installed electric motor when designing an installation. Restriction of the air inflow space may be affect motor cooling and ultimately result in a premature insulation system failure scenario. Note that motors used in enclosed or confined spaces may also need a general de-rating factor.

| Minimum rear space behind fan cowl | |
|------------------------------------|------------|
| Motor Frame | Minimum mm |
| 160 | 40 |
| 180 | 50 |
| 200 | 60 |
| 225 | 80 |
| 250 | 110 |
| 280 | 150 |
| 315 / 355 | 200 |

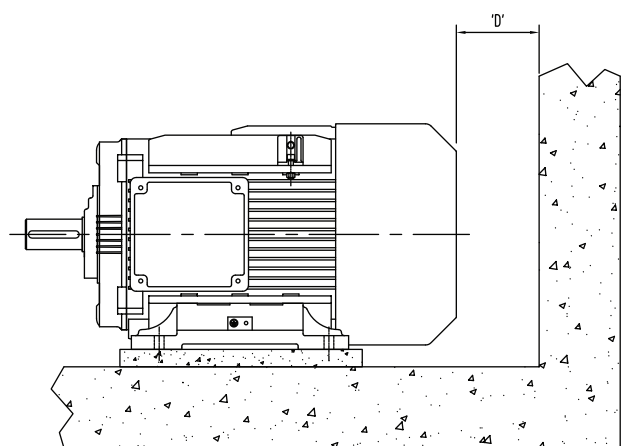

VSD APPLICATIONS & FORCED VENTILATION

All EMT OMEC Premium series high efficiency electric motors are suitable for use with electronic soft starter and inverter based Variable Speed Drives (VSDs).

As a general rule of thumb an S1 rated motor may be used in a constant torque application at speeds between 25Hz and 60Hz (415V) without specific modifications. Speeds over 60Hz will result in an available torque drop off and a rated kW upgrade may be required to cope with the load demand. At speeds below 25Hz the integral cooling fan efficiency drops to the point that an additional fixed speed forced ventilation cooling fan may be required to ensure adequate cooling airflow is maintained. In these instances above, where an application approaches these characteristics we recommend that you contact our engineers for specific application advice.

Further to the cooling requirements of electronically speed adjusted motors it may be required to include insulated bearings, bearing housings, earth brushes or a combination of the above to limit the potential bearing damage due to the presence of circulating eddy current spikes created by PWM inverter based controllers. All VSD drives have differing characteristics as do site specific supplies. As a broad rule of thumb we would suggest the inclusion of this type of protection for motors 75kw and above, again feel free to contact our Engineers for application specific advice.

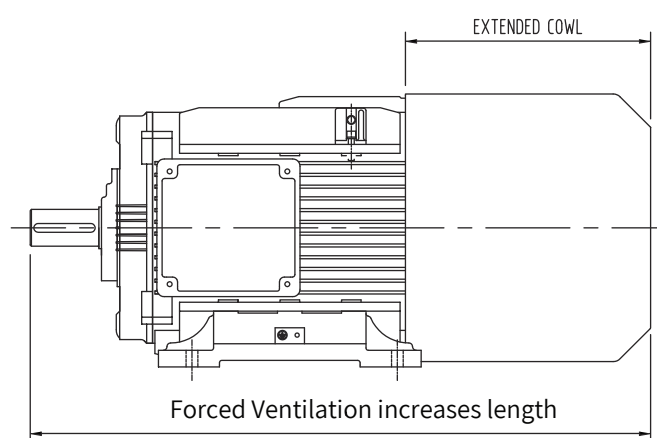

ROTOR DESIGN

All EMT OMEC Premium series electric motors have rotors constructed from high quality carbon steel. The resin coated lamination steel is carefully selected taking into account its mineral composition, electrical and mechanical properties to ensure that the rotating core is electrically efficient and reduces eddy current core losses to a minimum. The end ring design includes integral cooling fins which completes the internal air circuit. This helps the motor to effectively distribute the internal heat generated to the outer casing where heat loss is most effective. This reduces overall heat build up and lengthens the expected life of the motors resin impregnated insulation systems.

INSULATION SYSTEM

All EMT OMEC Premium series high efficiency motors are constructed using a vacuum impregnated class H insulation. The vacuum impregnated windings provides benefits such as

- Greater strength and rigidity
- Improved protection against moisture and foreign contamination
- Improved dielectrics
- Higher resistance to ground
- Lower maintenance
- Longer life
- Lower Total Cost of Ownership

All electrical designs are optimised to guarantee a Class B, 80°C working temperature rise above ambient at full load under normal operating conditions. Our class H insulation system has a working thermal limit of 125°C above the base 40°C ambient. This is an additional 20°C over the protection provided by the class F insulation systems found in other industrial motors. Further to this the class H insulation has a short term duration withstand rating of a further 15°C. This creates an insulation system with a maximum duty temperature of 165°C with transient peaks up to 180°C.

| | | | |
|--|------------|------------|------------|
| Hot spot margin | 10 | | |
| Permissible maximum winding temperature rise above base without derating | 80 | 105 | 125 |
| Rated Ambient temperature base | 40 | 40 | 40 |
| Maximum winding temperature limits | | | |
| Insulation Class | B - 130 °C | F - 155 °C | H - 180 °C |

This huge thermal safety margin for a motor with a design temperature rise of just 80°C maximum provides ultimate levels of protection for tough motor applications where unusually high ambient temperatures are common,

multiple start cycles are present, or heavily fluctuating loads create elevated temperature cycles. With heat related degradation being the key enemy of motor insulation integrity our Class H system ensures that our EMT OMEC Premium series motors will outlast most.

BEARINGS SIZE & REGREASING

All EMT OMEC motors are fitted with high quality branded bearings across the series. Frames 160 and up are regreasable at both the drive and non-drive ends. See the below tables for standard recommended regreasing intervals. Users should be aware that non standard duty applications in vertical installations, high ambient temperature, higher speed and high load applications may need reduced grease intervals.

The motors are supplied as standard with C3 clearance ball bearings in motors up to and including a 280 frame size with larger frames most commonly used on heavy duty applications using pulleys and belts have a ball / roller arrangement as standard. All frame sizes are designed in a manner that allows standard bearing selections to be changed to customise the motor to its specific duty. This includes the ability to interchange ball and roller bearings as well as angular contact bearings without modification to any motor component parts. Care should taken selecting bearings, it should be noted that roller bearings require a radial load to ensure correct operation and are in general not suitable for direct coupling arrangements as well as most 2 pole speed applications.

BALANCING & VIBRATION

Rotors are dynamically balanced using a half key in accordance with IEC 60034-14 standards. Motor frames 160 to 280mm are supplied balanced to grade normal. Larger motors frames are supplied balanced to grade reduced as standard. This high level of balance ensures low levels of vibration once installed ensuring longer bearing life and enhanced mechanical durability.

Typical Bearing sizes and Regrease Intervals - Premium Series IE3 range

| STANDARD HORIZONTAL MOUNT (IM1001) | | | | | | | | | |
|--------------------------------------|-------------|------------|--------------|---------|------------------|---------------------------|-------|-------|-------|
| Frame Size | Motor Poles | Motor Type | Bearing size | | Regrease qty (g) | Regrease Intervals- hours | | | |
| | | | ND | NDE | | 2P | 4P | 6P | 8P |
| 160 | 2 - 8 | M3 | 6309 C3 | 6309 C3 | 20 | 7500 | 15000 | 22500 | 29000 |
| 180 | 2 - 8 | M3 | 6311 C3 | 6311 C3 | 30 | 6000 | 13000 | 19500 | 26500 |
| 200 | 2 - 8 | M3 | 6312 C3 | 6312 C3 | 40 | 5700 | 11500 | 17000 | 23000 |
| 225 | 2 | M3 | 6313 C3 | 6313 C3 | 40 | 5700 | | | |
| | 4 - 8 | | 6313 C3 | 6313 C3 | 40 | | 10000 | 16000 | 21000 |
| 250 | 2 | M3 | 6314 C3 | 6314 C3 | 40 | 5000 | | | |
| | 4 - 8 | | 6314 C3 | 6314 C3 | 50 | | 9000 | 13500 | 18000 |
| 280 | 2 | M3 | 6314 C3 | 6314 C3 | 60 | 3000 | | | |
| | 4 - 8 | | 6317 C3 | 6317 C3 | 60 | | 8000 | 12000 | 16000 |
| 315 | 2 | Y2 | 6317 C3 | 6317C3 | 60 | 3000 | | | |
| | 4 - 8 | | 6319 C3 | 3619 C3 | 70 | | 7000 | 10000 | 14500 |
| | | | NU 319 | | | | | | |
| 355 | 2 | Y2 | 6317 C3 | 3617 C3 | 70 | 3000 | | | |
| | 4 - 8 | | 6322 C3 | 6320 C3 | 80 | | 7000 | 10000 | 14500 |
| | | | NU 322 | | | | | | |

Vibration Grades

| Rated Motor Speed rpm | Vibration Grade to IEC 60034-14 | Maximum RMS value of vibration velocity mm/s | |
|-----------------------|---------------------------------|--|------------|
| | | 160 to 225 | 250 to 355 |
| 600-3600 | Normal | 2.8 mm/s | 3.5 mm/s |
| 600-1800 | Reduced | 1.12 mm/s | 1.8 mm/s |
| 1800-3600 | | 1.8 mm/s | 2.8 mm/s |

PAINT & CORROSION PROTECTION

EMT OMEC Premium series high efficiency motors are differentiated from our other general motor product ranges by being finished in gloss electrical bright red orange RAL 2008 to a minimum DFT of 50 Microns. The paint process is a two coat based wet spray system as standard.

Special paint colours and processes may be requested to client or site specific specifications as and when required. This will need to be specified at the time of enquiry.

All of our Premium series motors are supplied with tropical protection of internal exposed bare metal surfaces. This ensures the durability of the motors when installed in both tropical and excessively humid industrial environments.

TERMINATIONS

Terminal voltages and connections are marked on each motor's stainless steel rating plate. These detail 50Hz and 60Hz ratings in for Star and Delta connection configurations. All motors are designed to have connection six terminals with interconnecting link bridge connectors allowing users to choose connection logic at the time of installation. Note current motor design standards require all motors above 112 frame to be delta connected for direct on line or VSD starting at standard 415V, 50Hz or 440V, 60Hz Australian voltages. Star configuration allows for 690V voltage applications.

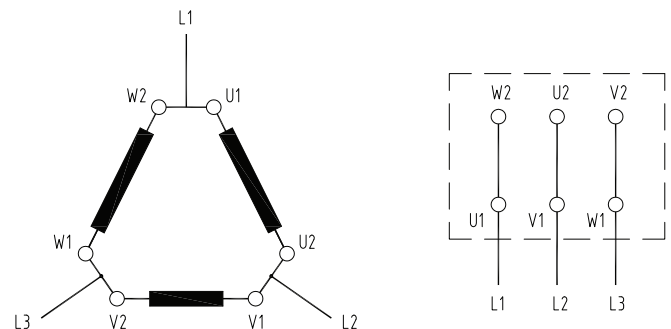

Delta Connected Winding 400 / 415V

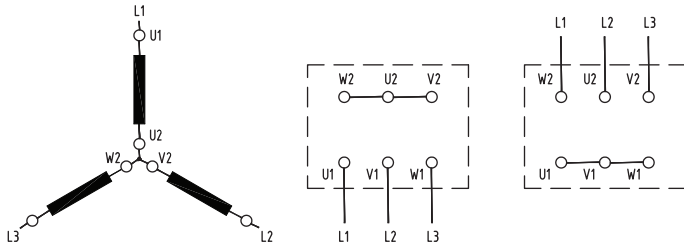

Star Connected Winding 690V

| Motor Frame Size | Winding Heater wattage |
|------------------|------------------------|
| 160 | 40 W |
| 180 | 40 W |
| 200 | 40 W |
| 225 | 54 W |
| 250 | 54 W |
| 280 | 54 W |
| 315 | 99 W |
| 355 | 99 W |

Heater Terminals in main or Separate Auxiliary Box

OVER TEMPERATURE PROTECTION

EMT OMEC Premium series high efficiency motors all are supplied with PTC thermistors already installed and terminated to an auxiliary terminal box. These motors have both an alarm 150°C and a 180°C trip thermistor as standard.

All motors can be upgraded to include additional thermistors, klixon type bi-metal thermal overloads or PT100 thermocouples on request.

HEATERS

All EMT OMEC premium series high efficiency motors can be equipped with strip heaters used to keep motors above ambient temperature when switched off. This helps prevent the build up of condensation within motor frames. These heaters are typically wound on to the winding overhang at one end of the motors stator winding. The leads are terminated into an auxiliary terminal box. Although mainly used in larger MV motors, larger frame LV motors can be equipped with 240V space heaters as an alternative, these are thermostatically controlled incaloy heaters preferred in some applications where a more robust heat source is required.

MODIFICATIONS & UPGRADES

EMT OMEC has its own engineering workshop. This facility allows us to perform modifications and upgrade works under the control of our ISO 9001:2015 accredited quality management systems.

Accordingly a wide range of modifications can be undertaken to create special purpose motors, make adaptor frames to facilitate the replacement of old Imperial frame motors. Additionally we customize motors with various optional features such as

- Addition of brakes and clutches
- Insulated bearings and earth brushes for VSD applications
- 150 / 180 °C Thermistors standard in aux' terminal box PT 100 thermal protection
- Forced ventilation units
- Anti condensation heaters
- Tacho generator and encoders
- Vibration and Temperature Smart sensors
- Customised colours
- Extended shafts

EMT OMEC Premium Series CAST IRON FRAME IE3 GENERAL PERFORMANCE DATA 50Hz 400V

- > Ratings 11kW to 315kW
- > IE3 efficiency at 75% and 100%
- > Multi-Voltage / Multi-Frequency Ratings
- > Right Hand side Terminal Box standard
- > Multi-Mount Terminal Box M3 series allows repositioning
- > Thermistors 1x 150 °C and 1x 180 °C as standard

- > Cast Iron Robust frames
- > TEFC IP66 standard
- > Class H Insulation
- > VI resin Impregnation and Tropicalisation
- > Regreasable bearing design 160 - 355 frame
- > B3, B5 and B35 Mounts

| Motor Part Code | Frame Design | Rated Output | | IE3 National Standard Efficiency | EMT OMEC Motor Performance | | Power Factor | | Full Load Amps 400V | Full Load Torque | Locked Current / Rated Current | Locked Torque / Rated Torque | Max Torque / Rated Torque | Moment of inertia(J) | Net weight |
|-----------------|--------------|--------------|------|----------------------------------|----------------------------|-----------|--------------|-----------|---------------------|------------------|--------------------------------|------------------------------|---------------------------|----------------------|------------|
| | | | | | 75% load | 100% Load | 75% load | 100% Load | | | | | | | |
| | | KW | RPM | % | % | % | cosØ | cosØ | Amps | Nm | % of FLC | % FLT | %Tmax | Kg-m ² | Kg |
| PHE 160M2 | M3 | 11 | 2958 | 91.2% | 93.2% | 93.1% | 0.887 | 0.907 | 18.8 | 35.5 | 8.03 | 3.05 | 3.71 | 0.0549 | 110 |
| PHE 160M4 | M3 | 11 | 1476 | 91.4% | 91.9% | 91.7% | 0.722 | 0.786 | 22.0 | 71.2 | 7.93 | 2.50 | 3.02 | 0.0724 | 120 |
| PHE 160L6 | M3 | 11 | 976 | 90.3% | 91.5% | 91.1% | 0.675 | 0.742 | 23.5 | 107.7 | 6.94 | 2.04 | 2.78 | 0.1452 | 135 |
| PHE 160MX2 | M3 | 15 | 2941 | 91.9% | 93.6% | 92.9% | 0.850 | 0.876 | 26.6 | 48.7 | 7.84 | 2.61 | 2.89 | 0.0635 | 125 |
| PHE 160L4 | M3 | 15 | 1476 | 92.1% | 92.9% | 92.7% | 0.713 | 0.780 | 29.9 | 97.1 | 7.99 | 2.87 | 3.38 | 0.0929 | 140 |
| PHE 180L6 | M3 | 15 | 982 | 91.2% | 92.1% | 92.0% | 0.700 | 0.762 | 30.9 | 145.7 | 6.45 | 2.07 | 3.10 | 0.2285 | 175 |
| PHE 160L2 | M3 | 18.5 | 2941 | 92.4% | 93.6% | 93.1% | 0.858 | 0.880 | 35.6 | 60.1 | 7.67 | 2.25 | 3.14 | 0.0725 | 140 |
| PHE 180M4 | M3 | 18.5 | 1477 | 92.6% | 93.4% | 93.3% | 0.741 | 0.798 | 35.9 | 119.6 | 7.89 | 2.50 | 3.69 | 0.1350 | 175 |
| PHE 200L6 | M3 | 18.5 | 984 | 91.7% | 92.3% | 92.3% | 0.712 | 0.774 | 37.4 | 179.5 | 7.47 | 2.42 | 3.14 | 0.3420 | 220 |
| PHE 180M2 | M3 | 22 | 2953 | 92.7% | 93.4% | 93.2% | 0.849 | 0.875 | 39.0 | 71.1 | 7.80 | 2.72 | 3.58 | 0.1025 | 175 |
| PHE 180L4 | M3 | 22 | 1478 | 93.0% | 93.4% | 93.5% | 0.719 | 0.789 | 43.0 | 142.1 | 7.99 | 2.47 | 3.80 | 0.1360 | 185 |
| PHE 200LX6 | M3 | 22 | 982 | 92.2% | 92.6% | 92.5% | 0.725 | 0.784 | 43.8 | 213.7 | 7.64 | 2.37 | 3.14 | 0.3860 | 230 |
| PHE 200L2 | M3 | 30 | 2963 | 93.3% | 93.7% | 93.3% | 0.831 | 0.861 | 53.9 | 96.6 | 7.60 | 2.41 | 3.47 | 0.1730 | 223 |
| PHE 200L4 | M3 | 30 | 1478 | 93.6% | 93.9% | 93.7% | 0.758 | 0.813 | 56.8 | 193.8 | 8.80 | 2.60 | 3.56 | 0.2450 | 240 |
| PHE 225M6 | M3 | 30 | 984 | 92.9% | 93.1% | 92.9% | 0.773 | 0.809 | 57.6 | 291.0 | 6.88 | 2.58 | 3.10 | 0.6250 | 300 |
| PHE 200LX2 | M3 | 37 | 2961 | 93.7% | 94.0% | 93.7% | 0.843 | 0.872 | 65.4 | 119.3 | 7.69 | 2.35 | 3.40 | 0.1950 | 245 |
| PHE 225S4 | M3 | 37 | 1483 | 93.9% | 94.1% | 93.9% | 0.787 | 0.835 | 68.1 | 238.4 | 8.18 | 3.16 | 3.90 | 0.3900 | 300 |
| PHE 250M6 | M3 | 37 | 987 | 93.3% | 93.7% | 93.5% | 0.795 | 0.835 | 68.4 | 358.0 | 7.38 | 2.33 | 3.40 | 0.9850 | 425 |
| PHE 225M2 | M3 | 45 | 2959 | 94.0% | 94.3% | 94.1% | 0.825 | 0.862 | 80.1 | 145.2 | 7.70 | 2.30 | 3.51 | 0.3250 | 310 |
| PHE 225M4 | M3 | 45 | 1484 | 94.2% | 94.3% | 94.2% | 0.803 | 0.833 | 82.8 | 289.5 | 7.98 | 3.14 | 3.90 | 0.4500 | 330 |
| PHE 250M6 | M3 | 45 | 985 | 93.7% | 93.9% | 93.7% | 0.794 | 0.840 | 82.0 | 421.0 | 7.40 | 2.70 | 2.50 | 1.7320 | 450 |
| PHE 250M2 | M3 | 55 | 2969 | 94.3% | 94.5% | 94.3% | 0.879 | 0.891 | 94.5 | 176.9 | 7.13 | 2.03 | 3.30 | 0.3950 | 385 |
| PHE 250M4 | M3 | 55 | 1484 | 94.6% | 94.8% | 94.6% | 0.814 | 0.856 | 98.0 | 354.1 | 7.87 | 2.53 | 3.60 | 0.6400 | 400 |
| PHE 280S6 | M3 | 55 | 986 | 94.1% | 94.3% | 94.1% | 0.787 | 0.840 | 100.0 | 520.0 | 7.50 | 3.20 | 2.50 | 1.9650 | 475 |
| PHE 250M2 | M3 | 75 | 2968 | 94.7% | 94.9% | 94.8% | 0.867 | 0.884 | 124.6 | 241.3 | 8.10 | 2.39 | 3.15 | 0.6830 | 415 |
| PHE 250M4 | M3 | 75 | 1480 | 95.0% | 95.5% | 95.0% | 0.829 | 0.851 | 129.0 | 484.0 | 6.31 | 1.98 | 2.72 | 1.0450 | 425 |
| PHE 280M6 | M3 | 75 | 990 | 94.6% | 94.8% | 94.6% | 0.775 | 0.826 | 138.0 | 706.0 | 7.40 | 2.00 | 3.15 | 3.7230 | 580 |
| PHE 280S2 | M3 | 90 | 2978 | 95.0% | 95.5% | 95.5% | 0.858 | 0.880 | 155.0 | 288.5 | 7.85 | 2.44 | 3.75 | 0.7650 | 545 |
| PHE 280S4 | M3 | 90 | 1491 | 95.2% | 96.0% | 95.9% | 0.821 | 0.859 | 157.7 | 576.4 | 6.31 | 1.98 | 2.72 | 1.3960 | 600 |
| PHE 315S6 | Y2 | 90 | 990 | 94.9% | 95.3% | 95.1% | 0.784 | 0.830 | 164.5 | 853.0 | 7.60 | 2.00 | 3.12 | 4.5260 | 920 |
| PHE 280M2 | M3 | 110 | 2977 | 95.2% | 95.9% | 96.1% | 0.844 | 0.866 | 183.9 | 352.9 | 8.56 | 3.02 | 3.54 | 1.5580 | 600 |
| PHE 280M4 | M3 | 110 | 1488 | 95.4% | 95.8% | 95.4% | 0.834 | 0.859 | 186.5 | 705.8 | 7.50 | 2.24 | 3.05 | 1.5750 | 650 |
| PHE 315ML6 | Y2 | 110 | 990 | 95.1% | 95.3% | 95.2% | 0.786 | 0.830 | 198.8 | 1039.9 | 7.85 | 2.00 | 3.05 | 5.1570 | 1120 |
| PHE 315S2 | Y2 | 132 | 2973 | 95.4% | 95.4% | 95.4% | 0.894 | 0.906 | 220.5 | 424.2 | 7.04 | 1.81 | 3.18 | 1.7260 | 980 |
| PHE 315S4 | Y2 | 132 | 1486 | 95.6% | 96.3% | 95.9% | 0.879 | 0.890 | 278.7 | 1060.9 | 7.93 | 2.92 | 3.22 | 3.6780 | 1017 |
| PHE 315ML6 | Y2 | 132 | 991 | 95.4% | 96.3% | 96.0% | 0.794 | 0.837 | 237.1 | 1271.5 | 7.90 | 2.76 | 3.65 | 5.6850 | 1185 |
| PHE 315ML2 | Y2 | 160 | 2970 | 95.6% | 95.9% | 95.6% | 0.888 | 0.897 | 269.2 | 514.8 | 6.68 | 1.78 | 2.98 | 1.9410 | 1090 |
| PHE 315ML4 | Y2 | 160 | 1489 | 95.8% | 96.2% | 96.1% | 0.826 | 0.864 | 278.0 | 1026.8 | 8.00 | 2.95 | 4.14 | 4.4720 | 1085 |
| PHE 355ML6 | Y2 | 160 | 992 | 95.6% | 96.0% | 95.8% | 0.814 | 0.847 | 284.6 | 1540.5 | 7.12 | 1.87 | 3.25 | 9.5700 | 1705 |
| PHE 315ML2 | Y2 | 200 | 2966 | 95.8% | 96.3% | 96.0% | 0.902 | 0.906 | 331.7 | 644.2 | 6.41 | 1.87 | 3.01 | 2.2120 | 1190 |
| PHE 315ML4 | Y2 | 200 | 1487 | 96.0% | 96.5% | 96.3% | 0.863 | 0.885 | 338.9 | 1258.2 | 6.12 | 2.64 | 3.34 | 4.8560 | 1200 |
| PHE 355ML6 | Y2 | 200 | 991 | 95.8% | 96.2% | 96.0% | 0.816 | 0.849 | 354.0 | 1926.8 | 7.13 | 1.94 | 3.32 | 9.8900 | 1890 |
| PHE 355ML2 | Y2 | 250 | 2979 | 95.8% | 96.2% | 96.2% | 0.888 | 0.903 | 415.6 | 801.3 | 7.77 | 1.95 | 3.54 | 3.8490 | 1710 |
| PHE 355ML4 | Y2 | 250 | 1489 | 96.0% | 96.5% | 96.3% | 0.870 | 0.888 | 421.7 | 1603.3 | 7.40 | 2.29 | 3.48 | 7.3640 | 1740 |
| PHE 355ML6 | Y2 | 250 | 991 | 95.8% | 96.3% | 96.0% | 0.847 | 0.868 | 433.1 | 2410.6 | 6.74 | 1.76 | 2.97 | 11.1000 | 2000 |
| PHE 355ML2 | Y2 | 280 | 2973 | 95.8% | 96.2% | 96.0% | 0.897 | 0.909 | 462.9 | 899.3 | 6.93 | 1.68 | 3.11 | 3.9490 | 1870 |
| PHE 355ML4 | Y2 | 280 | 1487 | 96.0% | 96.8% | 96.5% | 0.880 | 0.893 | 468.9 | 1798.2 | 6.50 | 2.03 | 3.11 | 8.0140 | 1870 |
| PHE 355ML6 | Y2 | 280 | 990 | 95.8% | 95.8% | 95.4% | 0.827 | 0.858 | 494.0 | 2701.9 | 7.23 | 1.92 | 3.13 | 11.3000 | 2080 |
| PHE 355ML2 | Y2 | 315 | 2979 | 95.8% | 96.6% | 96.5% | 0.899 | 0.920 | 512.1 | 1009.5 | 8.12 | 2.09 | 3.78 | 3.9950 | 1870 |
| PHE 355ML4 | Y2 | 315 | 1487 | 96.0% | 96.5% | 96.5% | 0.860 | 0.882 | 534.2 | 2023.0 | 7.15 | 2.25 | 3.36 | 9.1000 | 1975 |

EMT OMEC Premium Series CAST IRON FRAME IE3

GENERAL PERFORMANCE DATA 50Hz 400V

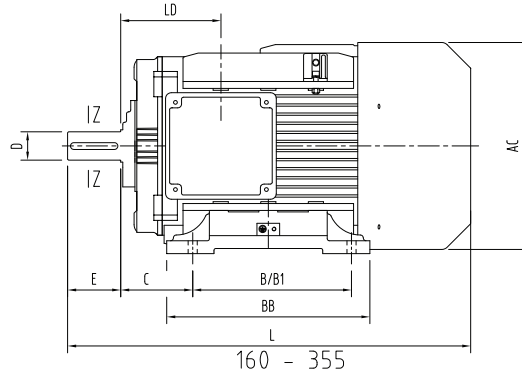
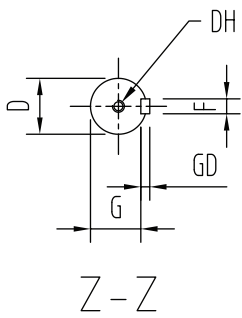

B3-Foot mount

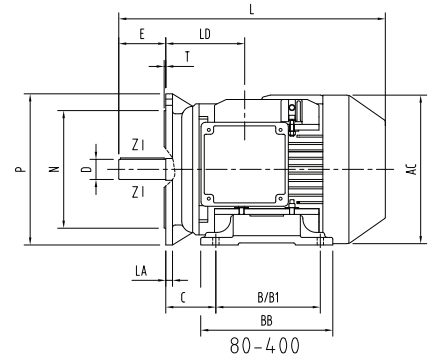

B5 / B35 Foot / Flange

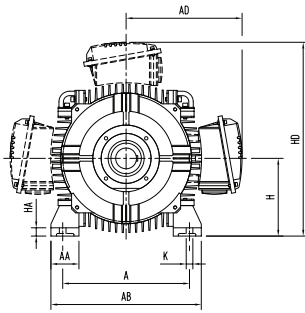

160 - 355

B3 Foot mount end view

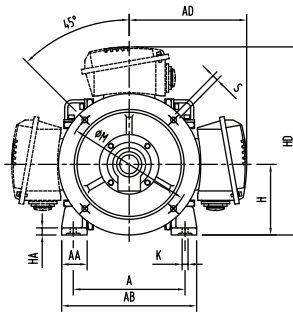

160-200

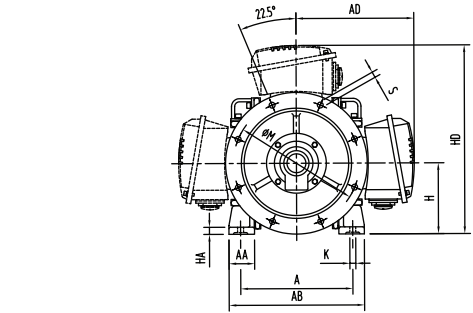

225-355

B5 Flange mount dimensions end view

| Frame Size | Pole | Frame H | Shaft Extension | | | | | Foot Centres | | | General Dimensions | | | | | | | | | | B5 Flange Dimensions | | | | | | |
|------------|------|---------|-----------------|-----|----|------|-----|--------------|-----|-----|--------------------|----|-----|-----|-----|-----|----|-----|-----|-----|----------------------|-----|-----|-----|--------|----|---|
| | | | D | E | F | G | DH | A | B | B1 | C | K | AA | AB | AC | BB | HA | HD | AD | LD | L | P | N | M | S | LA | T |
| 160M | 2-8 | 160 | 42 | 110 | 12 | 37 | M16 | 254 | 210 | - | 108 | 15 | 55 | 304 | 315 | 300 | 14 | 430 | 270 | 146 | 665 | 350 | 250 | 300 | 4 x 19 | 15 | 5 |
| 160L | 2-8 | 160 | 42 | 110 | 12 | 37 | M16 | 254 | 254 | - | 108 | 15 | 55 | 304 | 315 | 300 | 14 | 430 | 270 | 146 | 665 | 350 | 250 | 300 | 4 x 19 | 15 | 5 |
| 180M | 2-4 | 180 | 48 | 110 | 14 | 42.5 | M16 | 279 | 241 | - | 121 | 15 | 71 | 350 | 360 | 299 | 22 | 465 | 285 | 161 | 690 | 350 | 250 | 300 | 4 x 19 | 15 | 5 |
| 180L | 2-8 | 180 | 48 | 110 | 14 | 42.5 | M16 | 279 | 279 | - | 121 | 15 | 71 | 350 | 360 | 337 | 22 | 465 | 285 | 161 | 730 | 350 | 250 | 300 | 4 x 19 | 15 | 5 |
| 200L | 2-8 | 200 | 55 | 110 | 16 | 49 | M20 | 318 | 305 | - | 133 | 19 | 76 | 388 | 400 | 368 | 22 | 535 | 335 | 186 | 780 | 400 | 300 | 350 | 4 x 19 | 17 | 5 |
| 225S | 4-8 | 225 | 60 | 140 | 18 | 53 | M20 | 356 | 286 | - | 149 | 19 | 81 | 430 | 450 | 368 | 22 | 580 | 355 | 189 | 810 | 450 | 350 | 400 | 8 x 19 | 20 | 5 |
| 225M | 2 | 225 | 55 | 110 | 16 | 49 | M20 | 356 | 311 | - | 149 | 19 | 81 | 430 | 450 | 393 | 22 | 580 | 355 | 189 | 820 | 450 | 350 | 400 | 8 x 19 | 20 | 5 |
| 225M | 4-8 | 225 | 60 | 140 | 18 | 53 | M20 | 356 | 311 | - | 149 | 19 | 81 | 430 | 450 | 393 | 22 | 580 | 355 | 189 | 850 | 450 | 350 | 400 | 8 x 19 | 20 | 5 |
| 250M | 2 | 250 | 60 | 140 | 18 | 53 | M20 | 406 | 349 | - | 168 | 24 | 94 | 484 | 485 | 445 | 30 | 645 | 395 | 207 | 911 | 550 | 450 | 500 | 8 x 19 | 22 | 5 |
| 250M | 4-8 | 250 | 70 | 140 | 18 | 58 | M20 | 406 | 349 | - | 168 | 24 | 94 | 484 | 485 | 445 | 30 | 645 | 395 | 207 | 911 | 550 | 450 | 500 | 8 x 19 | 22 | 5 |
| 280S | 2 | 280 | 65 | 140 | 18 | 58 | M20 | 457 | 368 | - | 190 | 24 | 101 | 542 | 550 | 485 | 30 | 705 | 425 | 215 | 940 | 550 | 450 | 500 | 8 x 19 | 22 | 5 |
| 280S | 4-8 | 280 | 80 | 140 | 20 | 67.5 | M20 | 457 | 368 | - | 190 | 24 | 101 | 542 | 550 | 485 | 30 | 705 | 425 | 215 | 1015 | 550 | 450 | 500 | 8 x 19 | 22 | 5 |
| 280M | 2 | 280 | 65 | 140 | 18 | 58 | M20 | 457 | 419 | - | 190 | 24 | 101 | 542 | 550 | 536 | 30 | 705 | 425 | 215 | 990 | 550 | 450 | 500 | 8 x 19 | 22 | 5 |
| 280M | 4-8 | 280 | 80 | 140 | 20 | 67.5 | M20 | 457 | 419 | - | 190 | 24 | 101 | 542 | 550 | 536 | 30 | 705 | 425 | 215 | 1065 | 550 | 450 | 500 | 8 x 19 | 22 | 5 |
| 315S | 2 | 315 | 65 | 140 | 18 | 58 | M20 | 508 | 406 | - | 216 | 28 | 120 | 630 | 625 | 570 | 45 | 845 | 530 | 257 | 1170 | 660 | 550 | 600 | 8 x 24 | 22 | 5 |
| 315S | 4-8 | 315 | 85 | 170 | 22 | 71 | M20 | 508 | 406 | - | 216 | 28 | 120 | 630 | 625 | 570 | 45 | 845 | 530 | 257 | 1200 | 660 | 550 | 600 | 8 x 24 | 22 | 5 |
| 315M | 2 | 315 | 65 | 140 | 18 | 58 | M20 | 508 | 457 | 508 | 216 | 28 | 120 | 630 | 625 | 680 | 45 | 845 | 530 | 257 | 1290 | 660 | 550 | 600 | 8 x 24 | 22 | 5 |
| 315M | 4-8 | 315 | 85 | 170 | 22 | 71 | M20 | 508 | 457 | 508 | 216 | 28 | 120 | 630 | 625 | 680 | 45 | 845 | 530 | 257 | 1320 | 660 | 550 | 600 | 8 x 24 | 22 | 5 |
| 315L | 2 | 315 | 65 | 140 | 18 | 58 | M20 | 508 | 457 | 508 | 216 | 28 | 120 | 630 | 625 | 680 | 45 | 845 | 530 | 257 | 1290 | 660 | 550 | 600 | 8 x 24 | 22 | 5 |
| 315L | 4-8 | 315 | 85 | 170 | 22 | 71 | M20 | 508 | 457 | 508 | 216 | 28 | 120 | 630 | 625 | 680 | 45 | 845 | 530 | 257 | 1320 | 660 | 550 | 600 | 8 x 24 | 22 | 5 |
| 355M | 2 | 355 | 75 | 140 | 20 | 67.5 | M24 | 610 | 500 | 560 | 254 | 28 | 120 | 730 | 700 | 750 | 52 | 970 | 615 | 284 | 1526 | 800 | 680 | 740 | 8 x 24 | 22 | 5 |
| 355M | 4-8 | 355 | 100 | 170 | 25 | 86 | M24 | 610 | 500 | 560 | 254 | 28 | 120 | 730 | 700 | 750 | 52 | 970 | 615 | 284 | 1556 | 800 | 680 | 740 | 8 x 24 | 22 | 5 |
| 355L | 2 | 355 | 75 | 140 | 20 | 67.5 | M24 | 610 | 500 | 560 | 254 | 28 | 120 | 730 | 700 | 750 | 52 | 970 | 615 | 284 | 1526 | 800 | 680 | 740 | 8 x 24 | 22 | 5 |
| 355L | 4-8 | 355 | 100 | 170 | 25 | 86 | M24 | 610 | 500 | 560 | 254 | 28 | 120 | 730 | 700 | 750 | 52 | 970 | 615 | 284 | 1556 | 800 | 680 | 740 | 8 x 24 | 22 | 5 |

Other EMT OMEC products and services

High Voltage Motors

- o High voltage motors at 3,3kV, 6,6kV and 11kV.
- o kW ratings from 400kW to 10,000kW
- o Cast Iron motors to 500mm frame approximately 1000kW
- o Fabricated frame motors to 1000mm and 10,000kW
- o Motors designed to suit application
- o All mounting arrangements B3 B5 B35 and Vertical
- o Slipring motors available in all mount variations
- o We manufacture bespoke new for old replacements

Standard IE2 Low Voltage Motors

- o Single phase CRCS and CR motors to 2,2kW
 - o 0.18kW to 2,2kW, 2 and 4 Pole Speeds
 - o Class F with B rise
 - o B3, B5, B35, B14A and B14B mounts available
 - o IP 55 Multi Mount design
- o Three Phase IE2 Aluminium Frame Motors 0,09kW to 15kW
 - o 0,09 to 315kW ratings, 2, 4 and 6 Pole Speeds
 - o Class F with B rise
 - o IP 55 / 56 Design
 - o B3, B5, B35, B14A and B14B mounts available
 - o IP 55 Multi Mount design
- o Three Phase IE2 Cast Iron Frame Motors 2,2kW to 315kW
 - o 2,2 to 315kW ratings, 2, 4 and 6 Pole Speeds
 - o Class F with B rise
 - o B3 and B35 mounts available
 - o IP 55 / 56 Design
- o Nema Frame 56C frame motors
 - o Available in single and three phase
 - o Various common speeds and kW

Variable Speed Drives

- o Full range to suit all EMT OMEC motors
- o Single phase VSDs 240V to three phase 240V
- o Three phase drives all voltages
- o Various IP ratings available as well as full cabinets

Motor repair services

- o Full Motor rewind and repair facility within our own works
- o Motor service contracts undertaken
- o Installation and alignment services
- o Fabrication of special mounting bases adaptors

Engineering Services

- o General Mechanical and Electrical engineering services
- o Machining of special components
- o Maintenance Services and Contracts
- o Asset Management

EMT Projects

- o EMT's project division undertakes complete plant upgrade projects.
- o The team has many years of experience in the maintenance and upgrade of Plant and Equipment and can also undertake longer term project based work.

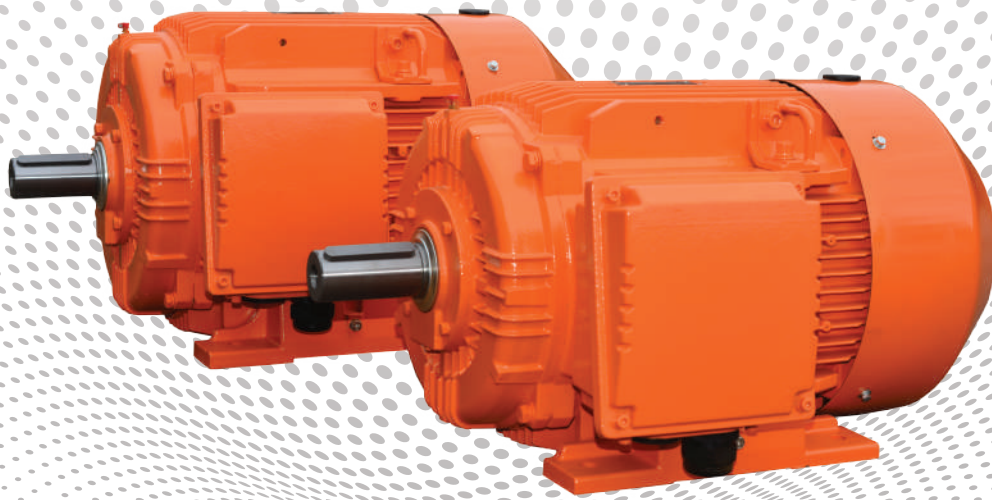

EMT OMEC Pty Ltd
114 Station Rd Seven Hills
NSW 2147, Australia

Phone: +61 (2) 9838 8181
Fax: +61 (2) 9838 8421

sales@emtomec.com.au
enquiries@emtomec.com.au
www.emtomec.com.au